



AMERICAN FITTINGS Corporation

Made in the USA Since 1946

Industrial SPEC-*grade*TM
Armored / Metal Clad FMC
Steel Connector
3/8" to 3/4"

FLEX Series Industrial SPEC-*grade*TM AC-MC Connectors

Solid Steel Fully Machined Connectors

Certified Made in the USA

For Use with Armored or Flex Metal Clad Conduit

Superior Life & Performance Over Zinc Die Cast and Malleable Iron Products

Unique Saddle Design Allows Industrial Strength Grip on FMC and Armored Cable

Solid Steel Body and Hex Nut Design Allows Full Strength Torque of Steel Screw

Solid Machined Steel Fully Zinc Plated

Furnished with UL Component Temperature Rated 150°C Insulated Throat and

Industrial Grade Locknut

Secure *GripTight, GripRight Connection*SM to Enclosure or Box

Save Time on Every Connection!

Why Bite Tight, When You Can Grip Tight, Grip RightSM

Superior Grip and Hold on Flex Conduit.

Unlike Inferior Die Cast Connectors,

Our Flex Fittings Will NOT Crack or Deform During Installation.

SPEC-*grade*TM

Designed to

GRIP Tight, GRIP RightSM

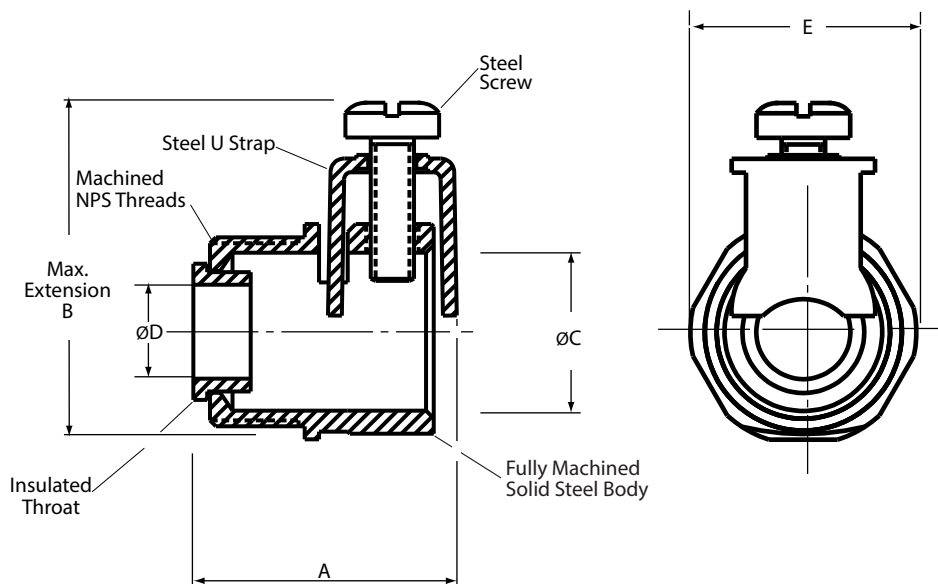
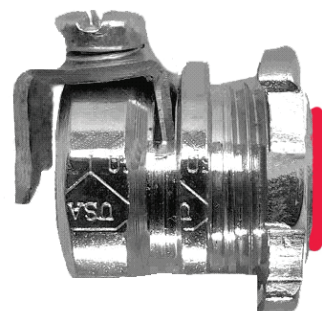

FLEX Series Industrial SPEC-*grade* AC-MC Connectors

Cable Range AC Cable Size MC Cable Size

Catalog #	Trade Size	Knockout	A	B	C	D	E	Min.	Max.	Min.	Max.	Min.	Max.
ACMC 38	3/8"	1/2"	1-3/16"	1-1/2"	11/16"	3/8"	.97"	.38"	.66"	14/2	10/4	14/2	10/4
ACMC 50	1/2"	1/2"	1-3/8"	1-3/4"	15/16"	9/16"	1.17"	.63"	.92"	8/3	6/4	10/4	6/3
ACMC 75	3/4"	3/4"	1-13/32"	2"	1-5/32"	3/4"	1.40"	.91"	1.12"	6/4	4/3	6/4	3/4

Be Sure to Ask About Our Revolutionary SPEC-*flex* FMC Connector, It Installs Without a Tool.

amftgs.com

t: 800.221.5268

e: info@amftgs.com